

CONTROL VALVE
TYPE VA3033®

 **VALVEA**

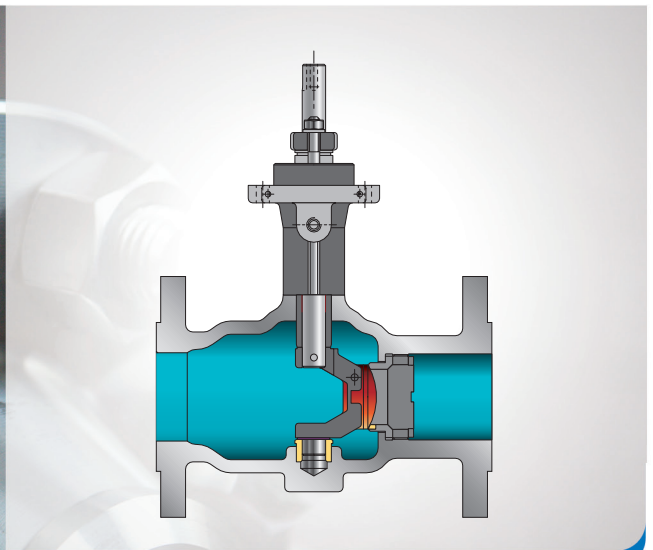

version 06/2020



VA3033 - ROTARY CONTROL GLOBE VALVE WITH ECCENTRICALLY SET ROTARY PLUG

Nominal dimensions

- DN 25 - DN 300
- 1" - 12"

Nominal pressure

- PN 10 - 40
- Class 150, Class 300

Construction

- single-ported valve with rotary plug, fluent regulation
- metal or soft seat
- rangeability 200 : 1

Medium temperature range

- -40°C to +450°C

Flow characteristic, Kvs values

- linear, equal-percentage
- 3 - 2 160 [m³/h]

Class of tightness (IEC 60 534 – 4)

- Class IV - standard, metal seat
- Class V - possible with metal seat

Body material

- steel, stainless steel according to EN, DIN or ASTM

Plug and seat material

- stainless steel
- stellite or plasma nitridation possible

Connection

- flange
- flangeless "sandwich"

Actuators

- pneumatic - diaphragm, piston
- electro-hydraulic
- electric
- hydraulic

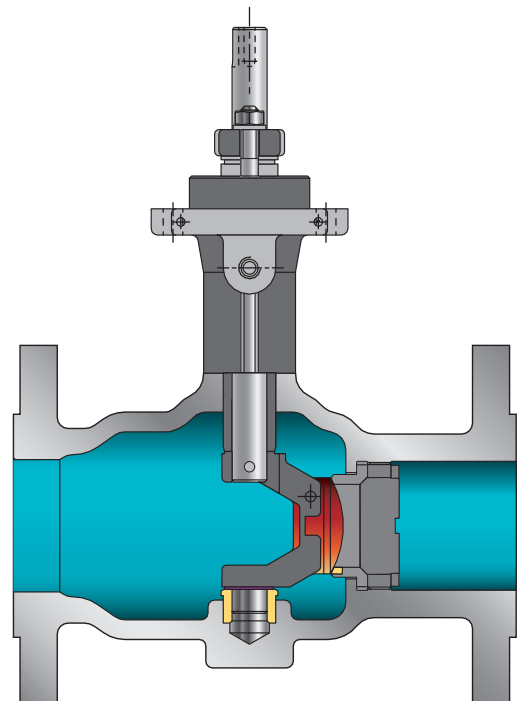

USE

Rotary plug control valves **VA3033** represent the design of valves, where change in flow ratio is achieved by eccentrically set rotary plug. Such structures are particularly useful for control of flow under heavy-duty conditions, with high probability of cavitation and erosion. High rangeability (200:1) and wide range of material and design variants make them ideal for application in many branches of industry, such as power generation, metallurgy, chemical and petroleum industry, food industry, paper industry, etc.

FEATURES

- one-piece valve body (cast with bonnet), no static or dynamic sealing except shaft sealing chamber
- no "detachment effect" between plug and seat
- possibility of changing Kvs without exchanging plug or seat
- easy replacement of rotary, symmetrical plug
- elongated bonnet allows application of double sealing for shaft, meeting "low emission" standards equal to TA-LUFT condition
- the same Kvs coefficients for "hard" and "soft" seats
- leakage class less than 0.01% Kvs for "hard" seats (metal-metal)
- same flow direction for "hard" and "soft" seats
- valve-actuator connection accessible from outside, which allows pivoting actuator to valve axis by 90° increments
- special executions: with heat jacket, erosion-proof, for crystallizable media

VA3033® – is a trademark registered by Patent Office.

DESIGN AND TECHNICAL SPECIFICATION

Body (1)	flanged or flangeless, cast in cast steel or stainless steel.
Nominal sizes:	DN 25; 40; 50; 80; 100; 150; 200; 250; 300
Nominal pressure:	PN10; 16; 25; 40 as per EN 1092-1:2004; ISO 7005-1:2002 CL150, CL300 as per ANSI B16.5; 1996

Steel flanges CL150; CL300 are so designed that they can be assembled with flanges executed per American standards ANSI / ASME B16.5 and MSS SP44. In American standards flanges are identified with nominal values in "Classes", to which nominal pressure (PN) values correspond. Equivalent identifications as per PN are:

CL150 - PN 20 a CL300 - PN 50

Table 1. Nominal pressures and connections

Nominal pressure	FACING TYPE OF FLANGES			
	Raised Face	Groove	Recess	Ring-joint
	Identification			
PN10, 16, 25, 40	B ²⁾	D	F	–
CL150		–	–	J (RTJ)
CL300		DL (D1 ¹⁾	F (F ¹⁾	

¹⁾ only for CL300

²⁾ B1 - (Ra=12.5 mm, concentric surface structure "C"), B2 – (Ra as agreed with the customer)

() - identification of connections as per ASME B16.5

Face-to-Face dimension:

- a) flanged valves as per EN 60534-3-1:2000; Table 12,
as per ANSI B16.10:1992; Table 12,
- b) flangeless (sandwich) as per EN 60534-3-2:2002

Bridge (2) – functions as rotary closure, cast in grey iron or steel (welded),

Valve plug (3) – working part in the form of globe section:

- flow characteristic: – linear (L)
– equal percentage (P) only with positioner
- rangeability: 200 : 1



- Valve seat (4)**
 - loosely resting in body opening; susceptible to fitting to spherical cap of valve plug
 - hard, tightness class IV. as per IEC 60534-4
 - soft (with PTFE sealing), tightness class VI. as per IEC 60534-4

- Screw plug (5)**
 - fixing seat to body (medium flow direction „under plug“)
 - in special executions the function is to prevent the erosion (medium flow direction „above plug“)

- Shaft (6)**
 - transmits torque from actuator to valve plug: burnished, with polished sealing interface.

- Guiding sleeves for plug (7) and shaft (8)** – function as slide bearings; surface hardened (CrN coating) or PTFE coated

- Packing (9)**
 - packing sets formed in various materials (PTFE-V; PTFE+graphite; braided or expanded graphite);
 - special “low emission” kit, with follower sprigs “TA-LUFT”

Table 2. Packing types with application ranges

Packing	Nominal pressure	Temperature [°C]
PTFE - V	PN 10-50 ANSI 150; 300	-46...+200
PTFE + Graphite		
PTFE - V / TA LUFT		
Graphite		+200...+250 (+200...+450)*
Graphite / TA-LUFT		

*) drive retracted from valve (extended yoke)

Table 3.1 - 3.5 Allowable working overpressure for materials at proper temperatures

		Material: GP240GH (1.0619) as per EN 10213-2							
PN/CL	Standard	Temperature [°C]							
		-10...50	100	150	200	250	300	350	400
		Maximum allowable working pressure [bar]							
PN10	EN 1092-1	10	9,2	8,8	8,3	7,6	6,9	6,4	5,9
PN16		16	14,8	14	13,3	12,1	11	10,2	9,5
CL150	EN 1759-1	17,3	15,4	14,6	13,8	12,1	10,2	8,4	6,5
PN25	EN 1092-1	25	23,2	22	20,8	19	17,2	16	14,8
PN40		40	37,1	35,2	33,3	30,4	27,6	25,7	23,8
CL300	EN 1759-1	45,3	40,1	38,1	36	32,9	29,8	27,7	25,7

Table 3.2

		Material: GX5CrNiMo (1.4408) as per EN 10213-4									
PN/CL	Standard	Temperature [°C]									
		10...50	100	150	200	250	300	350	400	425	450
		Maximum allowable working pressure [bar]									
PN10	EN 1092-1	10	10	9	8,4	7,9	7,4	7,1	6,8	-	6,7
PN16		16	16	14,5	13,4	12,7	11,8	11,4	10,9	-	10,7
CL150	EN 1759-1	17,9	16,3	14,9	13,5	12,1	10,2	8,4	6,5	5,6	4,7
PN25	EN1092-1	25	25	22,7	21	19,8	18,5	17,8	17,1	-	16,8
PN40		40	40	36,3	33,7	31,8	29,7	28,5	27,4	-	26,9
CL300	EN 1759-1	46,7	42,5	38,9	35,3	32,9	30,5	28,8	27,6	27,2	26,9



Table 3.3

		Material: G20Mn5 (1.6220) as per EN 10213-3					
PN	Standard	Temperature [°C]					
		-40	100	150	200	250	300
		Maximum allowable working pressure [bar]					
PN10		6	6	3,8	3,6	3,48	3,4
PN16		16	16	10,1	9,6	9,28	9,07
PN25		25	25	15,8	15	14,5	14,2
PN40		40	28	28	27	26	25

Table 3.4

		Material: WCB as per ASTM A216								
PN/CL	Standard	Temperature [°C]								
		-10...50	100	150	200	250	300	350	375	400
		Maximum allowable working pressure [bar]								
PN10	EN 1092-1	10	10	9,7	9,4	9	8,3	7,9	7,7	6,7
PN16		16	16	15,6	15,1	14,4	13,4	12,8	12,4	10,8
CL150	EN 1759-1	19,3	17,7	15,8	14	12,1	10,2	8,4	7,4	6,5
PN25	EN1092-1	25	25	24,4	23,7	22,5	20,9	20	19,4	16,9
PN40		40	40	39,1	37,9	36	33,5	31,9	31,1	27
CL300	EN 1759-1	50	46,4	45,1	43,9	41,8	38,9	36,9	36,6	34,6

Table 3.5

		Material: CF8M as per ASTM A351										
PN/CL	Standard	Temperature [°C]										
		-10...50	100	150	200	250	300	350	375	400	425	450
		Maximum allowable working pressure [bar]										
PN10	EN 1092-1	8,9	7,8	7,1	6,6	6,1	5,8	5,6	5,5	5,4	5,4	5,3
PN16		14,3	12,5	11,4	10,6	9,8	9,3	9	8,8	8,7	8,6	8,5
CL150	EN 1759-1	18,4	16	14,8	13,6	12	10,2	8,4	7,4	6,5	5,6	4,6
PN25	EN1092-1	22,3	19,5	17,8	16,5	15,5	14,6	14,1	13,8	13,6	13,5	13,4
PN40		35,6	31,3	28,5	26,4	24,7	23,4	22,6	22,1	21,8	21,6	21,4
CL300	EN 1759-1	48,1	42,3	38,6	35,8	33,5	31,6	30,4	29,6	29,3	29	29

Notes:

1. It is allowed to apply carbon steel up to -60°C, and acid proof steel up to -196°C, provided that working pressure is reduced respectively, working temperature impact tests are performed and cast is heat treated. Details are to be consulted with manufacturer.
2. Working pressure for intermediate temperature values can be calculated by interpolation.



Table 4. Listing of components with materials.

Item	Part name	Material			
1	Body	GP 240 GH; (1.0619)	WCB	GX5 Cr Ni Mo 19-11-2 ; (1.4408)	CF8M
2	Bridge				
* 3	Plug	X6CrNiMoTi 17-12-2 (1.4571); X6CrNiMoTi 17-12-2+ stellite X2CrNiMoTi 17-12-2 (1.4404); X2CrNiMoTi 17-12-2+stellite			
* 4a	Hard seat	X6CrNiMoTi 17-12-2 (1.4571); X6CrNiMoTi 17-12-2+ stellite X2CrNiMoTi 17-12-2 (1.4404); X2CrNiMoTi 17-12-2+stellite			
* 4b	Soft seat	X6CrNiMoTi 17-12-2+PTFE X2CrNiMoTi 17-12-2+PTFE			
5	Screw plug	X6CrNiMoTi 17-12-2 (1.4571)			
6	Shaft				
* 7	Guiding sleeve for plug	X6CrNiMoTi 17-12-2 (1.4571)+CrN X6CrNiMoTi 17-12-2+PTFE			
* 8	Guiding sleeve for shaft				
* 9	Packing kit	PTFE-V; PTFE+GRAPHITE; GRAPHITE			
10a, 10b	Sealing rings	FKM			
11	Sweep ring	VMQ			
12	Disc spring	12R10 (SANDVIK)			
13	Spacer Sleeve	X6CrNiMoTi 17-12-2 (1.4571)			
14	Lubricating sleeve				
15	Follower sleeve				
16	Pressing lever	X6CrNiMoTi 17-12-2 (1.4571);GX5CrNiMo 19-11-2 (1.4408)			
* 17	Cylindrical pin	X6CrNiMoTi 17-12-2 (1.4571)			
* 18	Conical pin				
19	Stud Bolt	8.8			A4-70
20	Nut	8			A4-70
Material standards					
Material	Standard nr.				
GP240GH (1.0619)	EN 10213-2				
WCB	ASTM A 216				
G20Mn5 (1.6220)	EN 10213-3				
GX5CrNiMo19-11-2 (1.4408)	EN 10213-4				
CF8M	ASTM A 351				
X6CrNiMoTi 17-12-2 (1.4571)	EN 10088				
X2CrNiMoTi 17-12-2 (1.4404)	EN 10088				
Notes					
*	- Spare part				

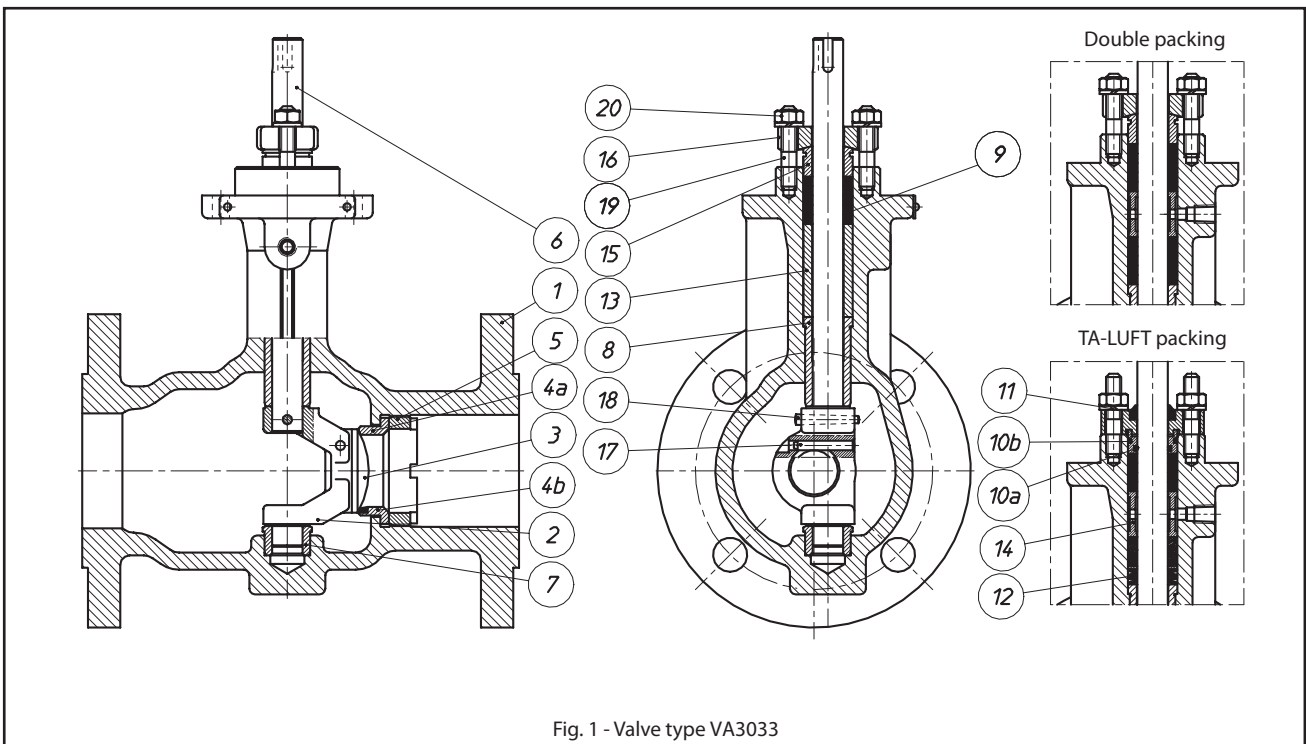

Fig. 1 - Valve type VA3033

FLOW RATIOS Kvs AND PRESSURE DROPS Δp

Table 5. „Hard“ Metallic seat (leakage class IV); reverse action actuator (air-to-open).

Actuator type						RP99-1-R (120cm ²)		RP99-2-R (240 cm ²)		RP99-3-R (780 cm ²)	
Spring range [kPa]						100-200	160-320	80-160	160-320	100-200	160-320
DN	Kvs 100%	Kvs 75%	Kvs 45%	** Kvs 120%	Seat diameter [mm]	Maximum pressure drop [MPa]					
25	15	11	7	18	18	50*	-	-	-	-	-
25	6	5	3	7	12	50*	-	-	-	-	-
40	40	30	18	48	28,5	50*	-	-	-	-	-
40	16	12	7	19	20	50*	-	-	-	-	-
50	60	45	27	72	38	50*	-	-	-	-	-
50	24	18	11	29	26	50*	-	-	-	-	-
80	150	113	68	180	58	11	32	50*	50*	-	-
80	60	45	27	72	38	33	50*	50*	50*	-	-
100	240	180	108	288	72	2	13	27	50*	-	-
100	96	72	43	115	48	11	36	50*	50*	-	-
150	500	375	225	600	110	-	-	9	23	50*	50*
150	200	150	90	240	72	-	-	25	50*	50*	50*
200	800	600	360	960	136	-	-	-	13	44	50*
200	320	240	144	384	88	-	-	-	37	50*	50*
250	1250	938	563	1500	170	-	-	-	5	20	45
250	500	375	225	600	110	-	-	-	17	50*	50*
300	1800	1350	810	2160	200	-	-	-	2	12	28
300	720	540	324	864	126	-	-	-	10	34	50*

Table 6. „Soft“ seat (leakage class VI); reverse action actuator (air-to-open)

Actuator type						RP99-1-R (120cm ²)		RP99-2-R (240 cm ²)		RP99-3-R (780 cm ²)	
Spring range [kPa]						100-200	160-320	80-160	160-320	100-200	160-320
DN	Kvs 100%	Kvs 75%	Kvs 45%	** Kvs 120%	Seat diameter [mm]	Maximum pressure drop [MPa]					
25	15	11	7	18	18	50*	-	-	-	-	-
25	6	5	3	7	12	50*	-	-	-	-	-
40	40	30	18	48	28,5	50*	-	-	-	-	-
40	16	12	7	19	20	50*	-	-	-	-	-
50	60	45	27	72	38	50*	-	-	-	-	-
50	24	18	11	29	26	50*	-	-	-	-	-
80	150	113	68	180	58	14	35	50*	50*	-	-
80	60	45	27	72	38	38	50*	50*	50*	-	-
100	240	180	108	288	72	5	16	30	50*	-	-
100	96	72	43	115	48	15	40	50*	50*	-	-
150	500	375	225	600	110	-	-	10	25	50*	50*
150	200	150	90	240	72	-	-	28	50*	50*	50*
200	800	600	360	960	136	-	-	-	15	38	50*
200	320	240	144	384	88	-	-	-	39	50*	50*
250	1250	938	563	1500	170	-	-	-	6	18	39
250	500	375	225	600	110	-	-	-	19	48	50*
300	1800	1350	810	2160	200	-	-	-	3	11	
300	720	540	324	864	126	-	-	-	11	30	50*

* – Do not exceed nominal pressure

** – For 120% setting it is recommended that listed pressure drops are reduced

In tables 5, 6, 10, theoretical acceptable pressure drops are included. Actual pressure drops with consideration of tolerance of spring manufacture and friction of internal parts of the actuator are lower than those given by 20%. Pressure drops chosen that way guarantee internal tightness of closing of the valves. Calculation ratios: $F_L=0,854$ $X_T=0,6$ $F_D=0,7$ $xF_Z=0,58$



Table 7. „Hard“ Metallic seat (leakage class IV); direct action actuator (air-to-close).

Actuator type						RP99-1-R (120cm ²)		RP99-2-R (240 cm ²)		RP99-3-R (780 cm ²)	
Spring range [kPa]						100-200	160-320	80-160	160-320	100-200	160-320
DN	Kvs 100%	Kvs 75%	Kvs 45%	** Kvs 120%	Seat diameter [mm]	Maximum pressure drop [MPa]					
25	15	11	7	18	18	50*	50*	-	-	-	-
25	6	5	3	7	12	50*	50*	-	-	-	-
40	40	30	18	48	28,5	50*	50*	-	-	-	-
40	16	12	7	19	20	50*	50*	-	-	-	-
50	60	45	27	72	38	50*	50*	-	-	-	-
50	24	18	11	29	26	50*	50*	-	-	-	-
80	150	113	68	180	58	11	50*	50*	50*	-	-
80	60	45	27	72	38	33	50*	50*	50*	-	-
100	240	180	108	288	72	2	24	27	50*	-	-
100	96	72	43	115	48	11	50*	50*	50*	-	-
150	500	375	225	600	110	-	-	9	38	50*	50*
150	200	150	90	240	72	-	-	25	50*	50*	50*
200	800	600	360	960	136	-	-	-	23	44	50*
200	320	240	144	384	88	-	-	-	50*	50*	50*
250	1250	938	563	1500	170	-	-	-	10	20	50*
250	500	375	225	600	110	-	-	-	29	50*	50*
300	1800	1350	810	2160	200	-	-	-	5	12	44
300	720	540	324	864	126	-	-	-	17	34	50*

Table 8. „Soft“ seat (leakage class VI); reverse action actuator (air-to-open).

Actuator type						RP99-1-R (120cm ²)		RP99-2-R (240 cm ²)		RP99-3-R (780 cm ²)	
Spring range [kPa]						100-200	160-320	80-160	160-320	100-200	160-320
DN	Kvs 100%	Kvs 75%	Kvs 45%	** Kvs 120%	Seat diameter [mm]	Maximum pressure drop [MPa]					
25	15	11	7	18	18	50*	50*	-	-	-	-
25	6	5	3	7	12	50*	50*	-	-	-	-
40	40	30	18	48	28,5	50*	50*	-	-	-	-
40	16	12	7	19	20	50*	50*	-	-	-	-
50	60	45	27	72	38	50*	50*	-	-	-	-
50	24	18	11	29	26	50*	50*	-	-	-	-
80	150	113	68	180	58	14	50*	50*	50*	-	-
80	60	45	27	72	38	38	50*	50*	50*	-	-
100	240	180	108	288	72	5	27	30	50*	-	-
100	96	72	43	115	48	15	50*	50*	50*	-	-
150	500	375	225	600	110	-	-	10	40	50*	50*
150	200	150	90	240	72	-	-	28	50*	50*	50*
200	800	600	360	960	136	-	-	-	50*	38	50*
200	320	240	144	384	88	-	-	-	50*	50*	50*
250	1250	938	563	1500	170	-	-	-	11	18	50*
250	500	375	225	600	110	-	-	-	30	48	50*
300	1800	1350	810	2160	200	-	-	-	6	11	44
300	720	540	324	864	126	-	-	-	19	30	50*

* – Do not exceed nominal pressure

** – For 120% setting it is recommended that listed pressure drops are reduced.

In tables 7, 8, 10, theoretical acceptable pressure drops are included. Actual pressure drops with consideration of tolerance of spring manufacture and friction of internal parts of the actuator are lower than those given by 20%. Pressure drops chosen that way guarantee internal tightness of closing of the valves. Calculation ratios: $F_L=0,854$ $X_T=0,6$ $F_D=0,7$ $xF_Z=0,58$

VALVE ACTUATORS

Rotary pneumatic valves, diaphragm and spring type RP99, with or without a handwheel - special designed to drive VA3033 valves.

Table 9. Types of rotary pneumatic actuators

Size	Diaphragm effective area [cm ²]	Spring ratio [kPa]	Rotation angle of output element (crankshaft)
RP99-1	120	100...200, 160...320	25° - 45° - 60° - 90°
RP-99-2	240	80...160, 160...320	
RP-99-3	780	100...200, 160...320	

ACTUATOR CHARACTERISTIC

- total reversibility of action, allowing change in function from "air-to-close - P" to "air-to-open - R", with no extra parts
- ability to mount actuator on valve, in various positions, pivoting with 90° increments
- option with a handwheel
- fixed diaphragm effective area, ensuring linear movement to pressure ratio
- optional NAMUR connections

DESIGN AND TECHNICAL SPECIFICATION OF ACTUATOR

- Body (21)** - among the basic components of actuator, designed to hold and assemble other components; - executed in grey or spheroidal iron.
- Yoke (28)** - connects valve to actuator; executed in grey iron or pressed in steel sheets and welded.
- Diaphragm (25) and spring (26) case** - creates a pressure chamber and springs case; executed as steel die; welded or cast in spheroidal iron.
- Diaphragm (31)** - executed in acrylic-butadiene rubber (NBR); reinforced with nylon insert.
- Diaphragm plate (24)** - formed in plastic or cast in aluminum alloy.
- Lever (22)** - transmits plane motion of membrane unit to rotary movement of crankshaft; executed in spheroidal cast-iron.
- Crankshaft (23)** - in connection with lever makes an output (driving) element of actuator in the form of rotating pin with key grooves; cast in alloy steel and heat processed.
- Spring (29)** - executed in construction spring steel; 2 springs for range 160 - 320 kPa.
- Bearing pin (27)** - connects lever and crankshaft; in special execution (extended) projects from the body and connects actuator to accessories (positioner, limit switches, etc.); executed in alloy steel (stainless steel)

BASIC TECHNICAL SPECIFICATION OF ACTUATOR

maximum supply pressure: 450 kPa
 control air connection: G 1/4"
 connection pipes diameter: Ø 6x1 (Ø 8x1)
 ambient temperature range: - 40°C ... + 80°C

control pressure change tolerance:
 - with no positioner: 4 % of nominal range
 - with positioner: 1,5 % of nominal range

hysteresis deviation:
 - with no positioner: 4 % of stroke range
 - with positioner: 1 % of stroke range

dead zone:
 - with no positioner: 2 % of nominal pressure range
 - with positioner: 1 % of nominal pressure range

optional accessories (on request):

- handwheel
- positioner
- air set
- three-way solenoid valve
- lock-up valve
- limit switches
- quick exhaust valve

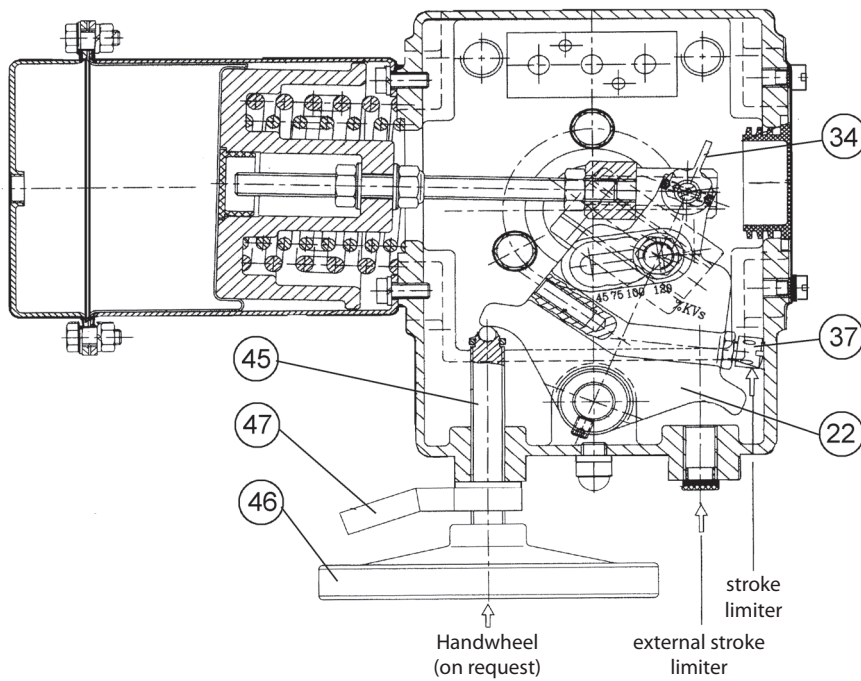
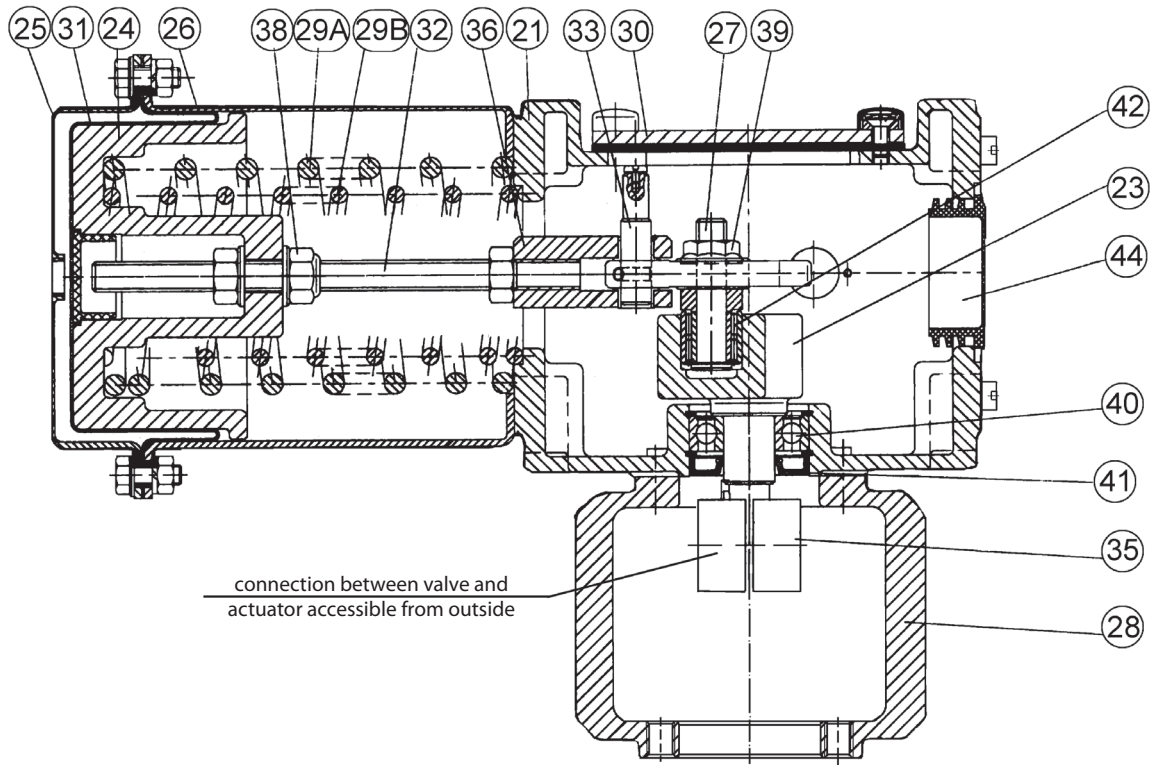

Item	Part name
21	Body
22	Lever
23	Crankshaft
24	Diaphragm plate
25	Diaphragm case
26	Spring case
27	Bearing pin
28	Yoke
29	Spring (A+B)
30	Front nameplate
31	Diaphragm
32	Screw
33	Fork pin
34	Stroke indicator
35	Connector
36	Fork
37	Stroke limiter
38	Adjusting nut
39	Securing nut
40	Ball bearing
41	Sealing ring
42	Needle bearing
44	Closure plug
45	Handwheel screw
46	Wheel
47	Counterlever

x - spare parts

Fig. 2 Rotary pneumatic actuator (spring and diaphragm) type RP99

Pneumatic actuators, rotary piston type

It is possible to apply rotary piston (spring or springless) actuators by any manufacturer, as required. For detailed technical specifications of actuators and completion methods refer to datasheets.

Electric actuators

In process installations where no pneumatic actuators can be applied, valves can be driven using electric rotary actuators of various types. For technical specifications refer to separate datasheets.

SPECIAL DESIGNS

Valve executions as per Fig. 3

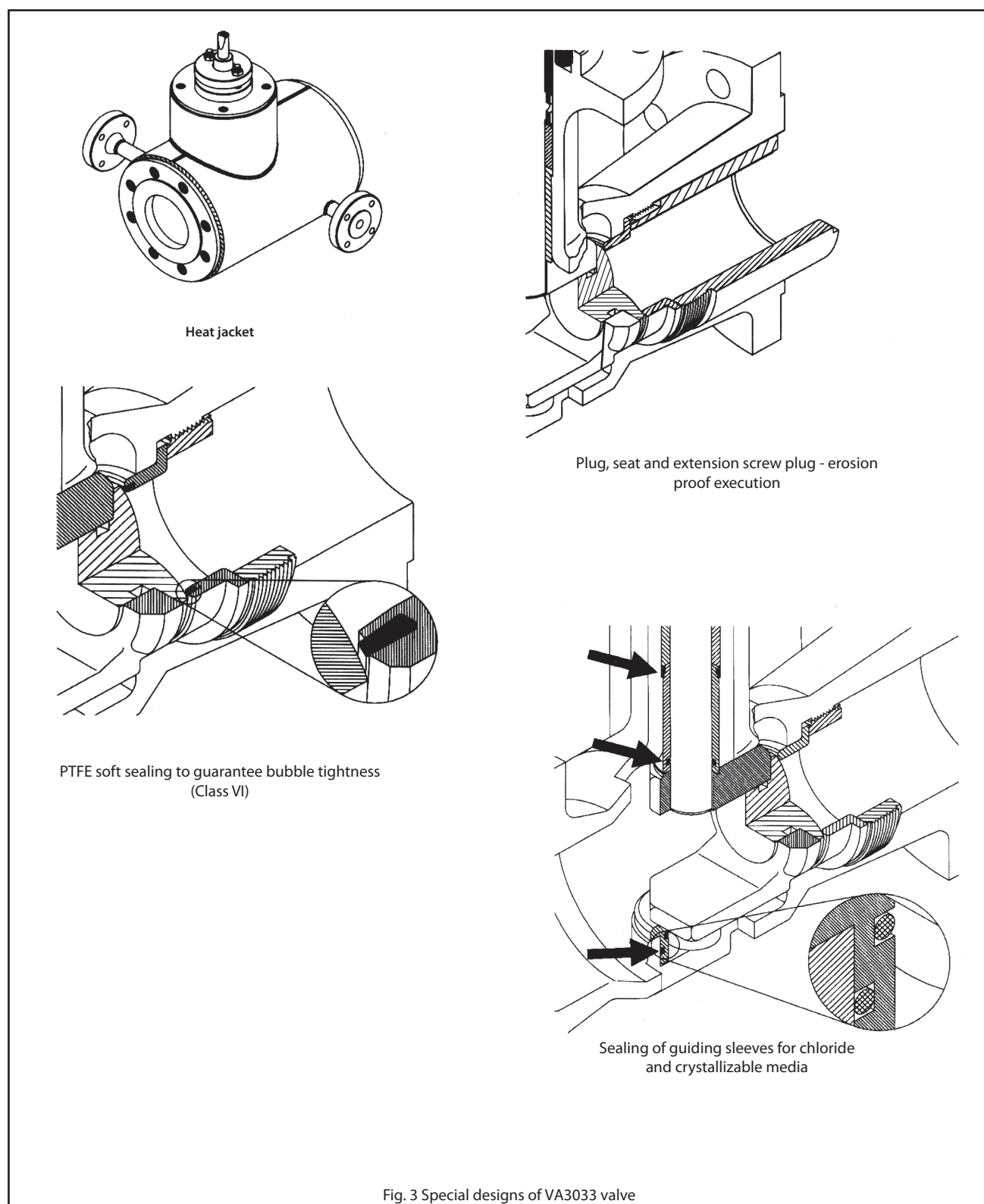
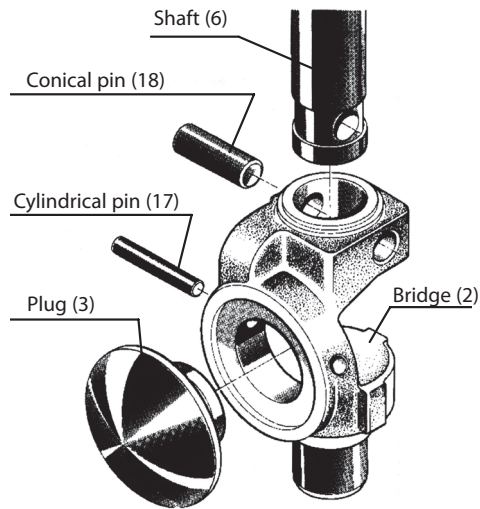

Fig. 3 Special designs of VA3033 valve



OPERATION PRINCIPLE:



Adjustment of rotation angle of actuator type RP99 (patent pending) via system of two levers.

Lever (22) attached to diaphragm plate (24) always turns by 30°, hence stroke, pressure range and positioner feedback lever position do not change.

With change in setting of bearing pin (27) turn angle of crankshaft (23) (and also valve shaft) changes too, within values 25°, 45°, 60° and 90°, which corresponds with changes in flow ratio values to 45%, 75%, 100% and 120% Kvs. In closed position of valve movement of bearing pin to crankshaft guide at the beginning of lever rotation is parallel, hence closed position of valve is maintained.

Connector (35), which connects actuator to valve shaft, allows turning of actuator to valve by each 90°, and since it is accessible from outside it eliminates the need for actuator or valve disassembly.

Required position (see Fig.4) can be set by manufacturer as per customer's request.

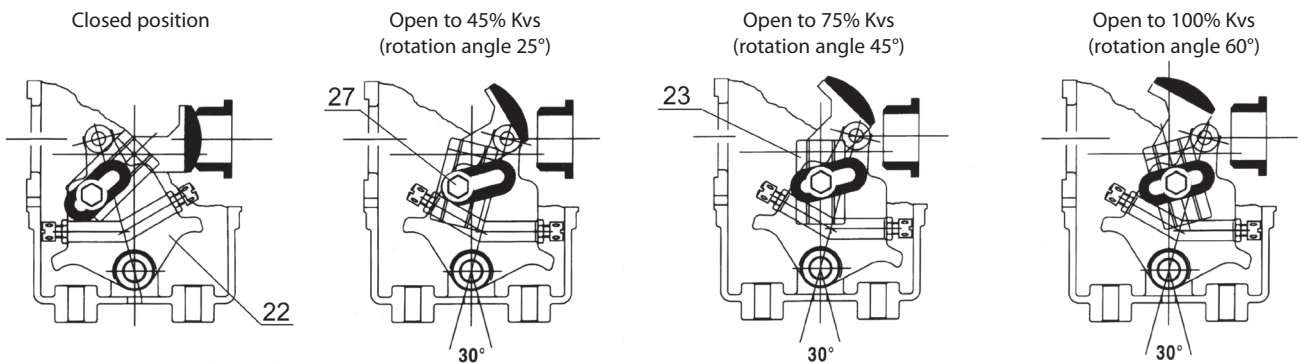

Fig. 4. Bearing pin (27) position on lever (22) regarding crankshaft (23) (valve shaft - Kvs) rotation angle.

1. Air-to-open mode (fail-to-close position)

2. Air-to-close mode (fail-to-open)

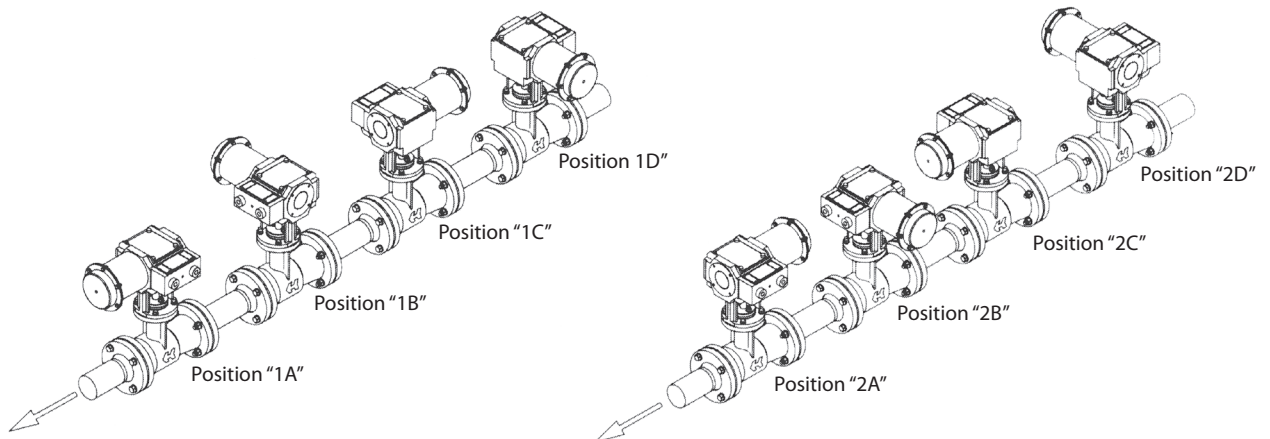

Fig. 5 Possible actuator type RP99 positions to valve axis.

EXTERNAL SIZES, END CONNECTION SIZES; WEIGHTS

Table 10. Valve end connection sizes.

DN	End connection as per ISO 5211	E	F	G
25...50	F07	83	16	55
80...100	F12	83	16	85
		116	28	
150	F14	113	28	100
		123	36	
200...300	F16	133	28	130
		120	36	

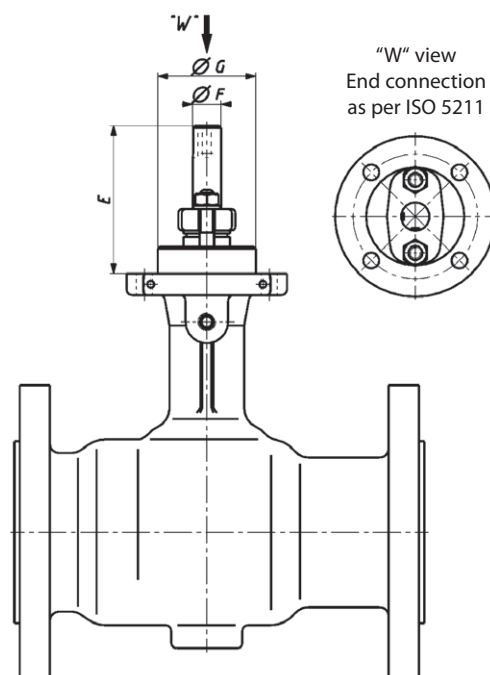

Table 11. Actuator type RP99 end connection sizes.

Size	Connection as per ISO 5211	L	K	$G_{+0,3}^{+0,5}$	F	S	Weight [kg]
99-1	F07	110	36	55	16	24	18
	F12			85			
99-2	F12	180	60	85	28	60	54
	F14			100			
	F16			130			
99-3	F14	200	60	100	36	31	189
	F16			130			

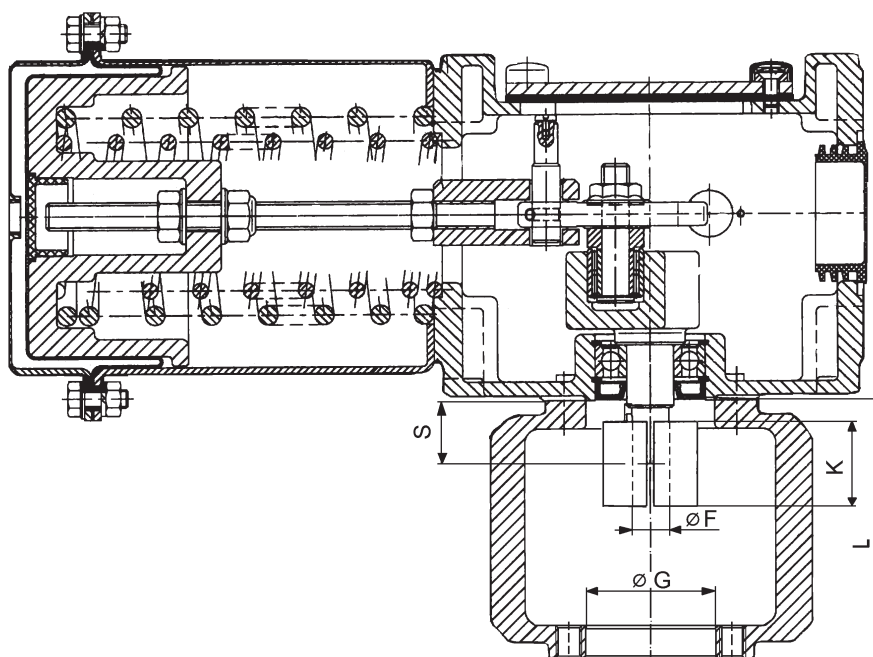
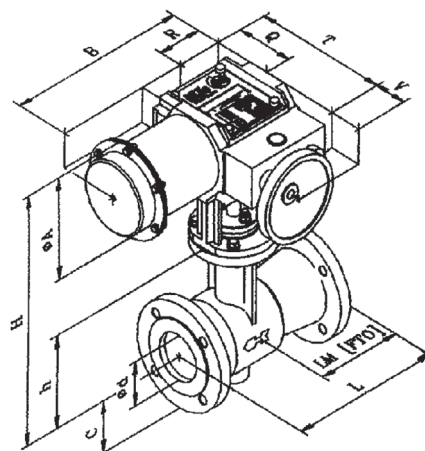

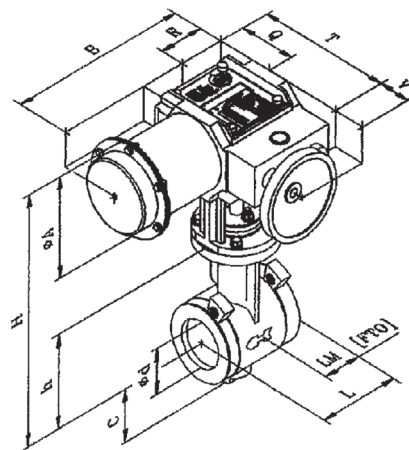

Table 12. Dimensions of valves with actuators type RP99.

DN	Flanges	Actuat.	H [mm]	h [mm]	d [mm]	A [mm]	L [mm]	LM [mm]	B [mm]	R [mm]	Q [mm]	V [mm]	T [mm]	Weight [kg]¹)
25	PN40	99-1	409	134	37	175	160	89	274	92	105	90	234	20
25	CL150	99-1	409	134	37	175	184	113	274	92	105	90	234	20
25	CL300	99-1	409	134	37	175	197	126	274	92	105	90	234	21
25	Sandw.	99-1	409	134	37	175	102	60	274	92	105	90	234	18
40	PN40	99-1	415	140	48	175	200	115	274	92	105	90	234	22
40	CL150	99-1	415	140	48	175	222	137	274	92	105	90	234	22
40	CL300	99-1	415	140	48	175	235	150	274	92	105	90	234	23
40	Sandw.	99-1	415	140	48	175	114	64	274	92	105	90	234	20
50	PN40	99-1	420	145	60	175	230	123	274	92	105	90	234	23
50	CL150	99-1	420	145	60	175	255	135	274	92	105	90	234	23
50	CL300	99-1	420	145	60	175	267	141	274	92	105	90	234	25
50	Sandw.	99-1	420	145	60	175	124	70	274	92	105	90	234	22
80	PN40	99-1	467	192	88	175	310	190	274	92	105	90	234	34
80	PN40	99-2	607	192	88	250	310	190	573	135	143	75	348	55
80	CL150	99-1	467	192	88	175	298	178	274	92	105	90	234	34
80	CL150	99-2	607	192	88	250	298	178	573	135	143	75	348	55
80	CL300	99-1	467	192	88	175	318	197	274	92	105	90	234	39
80	CL300	99-2	607	192	88	250	318	197	573	135	143	75	348	60
80	Sandw.	99-1	467	192	88	175	165	92	274	92	105	90	234	31
80	Sandw.	99-2	607	192	88	250	165	92	573	135	143	75	348	52
100	PN40	99-1	477	202	107	175	350	215	274	92	105	90	234	55
100	PN40	99-2	617	202	107	250	350	215	573	135	143	75	348	76
100	CL150	99-1	477	202	107	175	353	223	274	92	105	90	234	55
100	CL150	99-2	617	202	107	250	353	223	573	135	143	75	348	76
100	CL300	99-1	477	202	107	175	368	234	274	92	105	90	234	65
100	CL300	99-2	617	202	107	250	368	234	573	135	143	75	348	86
100	Sandw.	99-1	477	202	107	175	194	116	274	92	105	90	234	51
100	Sandw.	99-2	617	202	107	250	194	116	573	135	143	75	348	72
150	PN40	99-2	699	284	162	250	480	270	573	135	143	75	348	100
150	PN40	99-3	789	284	162	430	480	270	925	220	230	70	526	190
150	CL150	99-2	699	284	162	250	451	241	573	135	143	75	348	100
150	CL150	99-3	789	284	162	430	451	241	925	220	230	70	526	190
150	CL300	99-2	699	284	162	250	473	263	573	135	143	75	348	114
150	CL300	99-3	789	284	162	430	473	263	925	220	230	70	526	204
150	Sandw.	99-2	699	284	162	250	229	140	573	135	143	75	348	82
150	Sandw.	99-3	789	284	162	430	229	140	925	220	230	70	526	172
200	PN40	99-2	727	312	204	250	600	365	573	135	143	75	348	190
200	PN40	99-3	817	312	204	430	600	365	925	220	230	70	526	280
200	CL150	99-2	727	312	204	250	543	336,5	573	135	143	75	348	180
200	CL150	99-3	817	312	204	430	543	336,5	925	220	230	70	526	270
200	CL300	99-2	727	312	204	250	568	349	573	135	143	75	348	210
200	CL300	99-3	817	312	204	430	568	349	925	220	230	70	526	300
200	Sandw.	99-2	727	312	204	250	243	157	573	135	143	75	348	130
200	Sandw.	99-3	817	312	204	430	243	157	925	220	230	70	526	220
250	PN40	99-2	751	336	250	250	730	430	573	135	143	75	348	230
250	PN40	99-3	841	336	250	430	730	430	925	220	230	70	526	320
250	CL150	99-2	751	336	250	250	673	401,5	573	135	143	75	348	200
250	CL150	99-3	841	336	250	430	673	401,5	925	220	230	70	526	290
250	CL300	99-2	751	336	250	250	708	421	573	135	143	75	348	230
250	CL300	99-3	841	336	250	430	708	421	925	220	230	70	526	320
250	Sandw.	99-3	841	336	250	430	297	190	925	220	230	70	526	230
300	PN40	99-2	769	338	300	250	850	553	573	135	143	75	348	430
300	PN40	99-3	859	338	300	430	850	553	925	220	230	70	526	520
300	Sandw.	99-2	769	342	300	250	338 ²⁾	197,5	573	135	143	75	348	300
300	Sandw.	99-3	859	342	300	430	338 ²⁾	197,5	925	220	230	70	526	390



Flanged valve
Actuator RP99-1



Flangeless valve - Sandwich
Actuator RP99-1

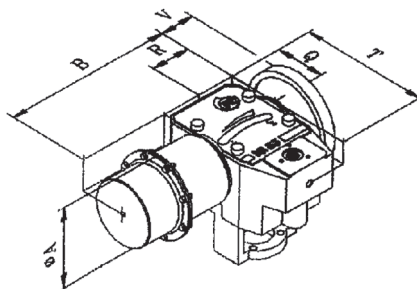

Actuator RP99-2
Actuator RP99-3

1) Valve weight (w/o actuators)
2) non-compliant with EN 60534-3-2





VALVEA s.r.o.

Sídlo firmy:

Oldřichovice 1044
739 61 Třinec
Česká republika
tel.: +420 558 321 088
email: info@valvea.eu
web: www.valvea.eu